



# DEAERATOR

SOLUTIONS.COM

OFFICE (913)384-2500 | CELL (913)648-7600 | INFO@DEAERATORSOLUTIONS.COM

## 1.5" THREADED SPRAY VALVE

MATERIAL: CF8M STAINLESS STEEL

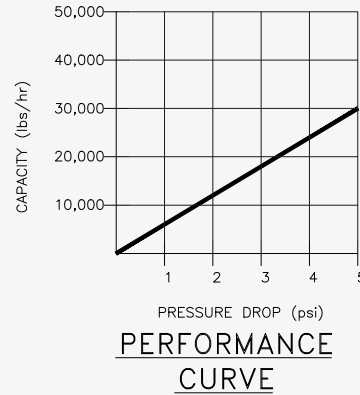
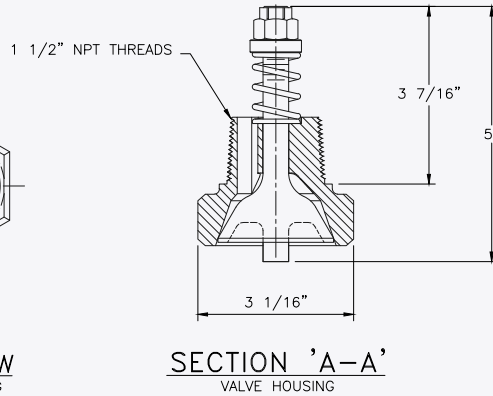
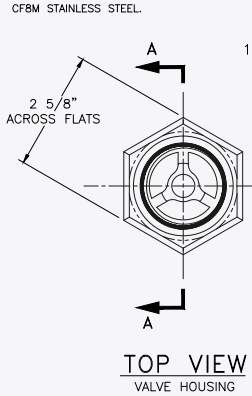

**Replaces all 1.5" Threaded Spray Valves (including: Worthington)**

**Materials** 316 SS per HEI  
**Flow** 0-35,000 lb/hr  
**Pressure Drop** 0-5 PSI  
**Weight** 2.5 lbs.  
**Size** 3 in x 3 in x 3 in



PROUD DISTRIBUTOR OF



*Kansas City Deaerator*  
C O M P A N Y

www.deaerator.com